

ToolPRO

1 YEAR
WARRANTY

Air



2HP

AIR COMPRESSOR

INSTRUCTION MANUAL

PLU: 723464



For service, spare parts or product information,
please contact: Smart Marketing Group Pty. Ltd

AUSTRALIA: 1300 660 457
NEW ZEALAND: 0800 474 876

VAIR COMPRESSOR
TP1000

VOLTAGE
230-240V AC - 50HZ

MOTOR
ELECTRIC 2HP

WATTAGE
1500W

NO LOAD SPEED
2800RPM

FREE AIR DELIVERY (FAD)
70L PER MINUTE

TANK SIZE	DUTY CYCLE
21L	75%

MAX. TANK PRESSURE
115PSI (8 BAR)

OUTLET PRESSURE
0PSI - 115PSI ADJUSTABLE

OIL TYPE
SAE30

NOISE RATING
71DB@5M LW@91DB

MOTOR / PUMP KICKS IN
90PSI

PRESSURE CYCLE STOPS	NUMBER OF OUTLETS
115PSI	1

2HP AIR COMPRESSOR

MODEL NO. TP1000

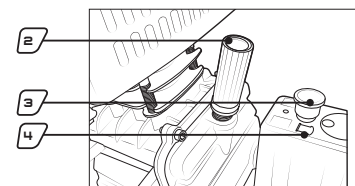
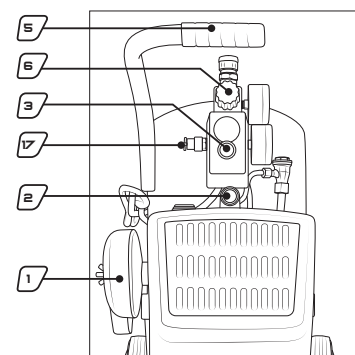
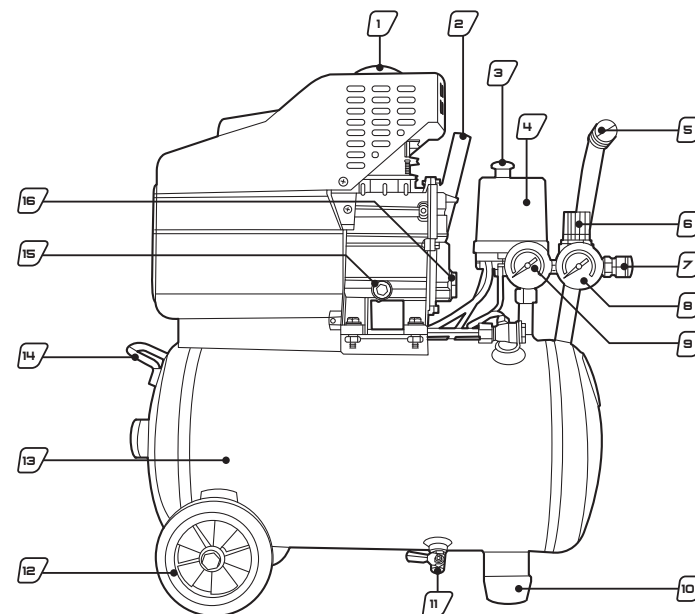

COMPONENTS AND CONTROLS

1. Air Filter
2. Oil Fill and Breather
3. On/Off Button (red colour)
4. Pressure Switch
5. Front Handle
6. Outlet Pressure Regulator
7. Air outlet fitting Nitto Style
8. Outlet Pressure Gauge
9. Tank Pressure Gauge
10. Rubber Stopper
11. Tank Drain Tap
12. Wheels
13. Tank
14. Carry Handle
15. Oil Drain Bolt
16. Oil Sight Glass
17. Safety Valve



Before using air compressor it should be carefully checked to determine that it will operate properly and perform its intended function.

- Check for broken or missing parts.
- The air compressor should be set up near to the user.
- Check any other condition that may affect the operation of the air compressor.
- Before you use your air compressor, make sure that the mains voltage complies with the specifications on the rating plate.
- A guard or any other part of the air compressor that is damaged should be properly repaired or replaced by an authorised service facility unless otherwise indicated in this instruction manual.

ASSEMBLY

UNPACKING

Carefully unpack your air compressor. This air compressor is bulky and heavy, two (2) person lift may be required. Dispose of all packing material in an environmentally responsible manner.

RUBBER STOPPER

To attach the rubber stopper to the bracket located on the bottom of the tank, Pic. 1;

1. Undo the nut and remove the split washer and small flat washer.
2. Push the bolt with the large flat washer on through the rubber stopper.
3. Push through the bracket and replace the small flat washer, split washer and nut.
4. Tighten the nut.

WHEELS

To attach wheel, Pic 2;

1. Undo the nut and remove the split and both flat washers.
2. Insert a bolt through the wheel and add a flat washer.
3. Push through the tank wheel bracket and replace flat washer, split washer and nut.
4. Tighten the nut and repeat for other wheel.

WARNING!
ENSURE THE AIR COMPRESSOR IS TURNED OFF AND DISCONNECTED FROM THE POWER SUPPLY BEFORE PERFORMING ANY OF THE FOLLOWING OPERATIONS.
ALWAYS KEEP THE AIR COMPRESSOR UPRIGHT.

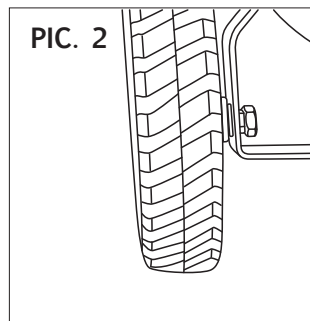
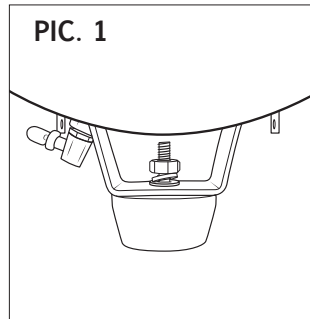

HANDLE

For this air compressor, the handle is already assembled.

WARNING! YOUR AIR COMPRESSOR IS FILLED WITH OIL.

OIL BREATHER

To fit the oil breather remove the transport plug and screw in the oil breather. Pic 3 and Pic 4.

CHECKING THE OIL LEVEL

Always check the oil level when the air compressor is on flat and level ground.

To confirm the oil level lift the back, handle end, up about 20cm, hold for about 1 minute and place back on ground.

Look at the sight glass (Pic. 5) and ensure the oil is top of the red dot on the sight glass, as per the "OIL LEVEL GAUGE" label.

Before each use, check the oil level and if at or below minimum requirements, top up with SAE30.

AIR FILTER

The supplied air filters must be used. Failure to do so may result in irreparable damage and will void the warranty. Pic 6.

1. Carefully screw supplied air filter into the threaded hole on the top of pump head. This only needs to be done up by hand. Do not use tools to tighten air filter.

NOTE: Do not OVER TIGHTEN as this may damage the air filter or cylinder head which will NOT be covered under warranty.

TO TURN YOUR AIR COMPRESSOR ON

Lift up the red ON / OFF button on top of the pressure switch. Pic. 7.

TO TURN YOUR AIR COMPRESSOR OFF

Push down the red ON / OFF button on top of the pressure switch. Pic. 8.

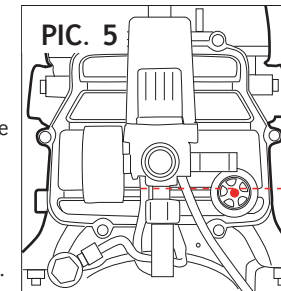
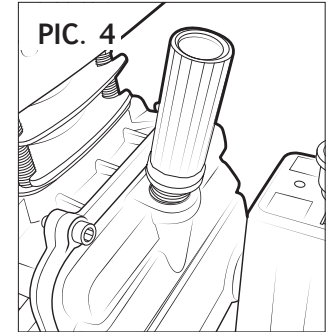
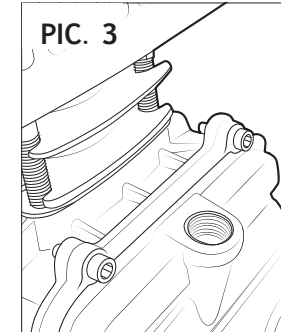

OVER FULL;
Drain some oil.
Recommended;
Oil level ok.
Fill with SAE30
Immediately
OIL LEVEL GAUGE

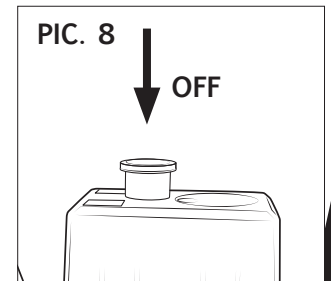
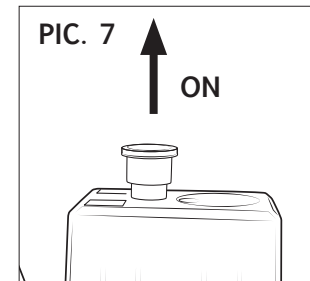
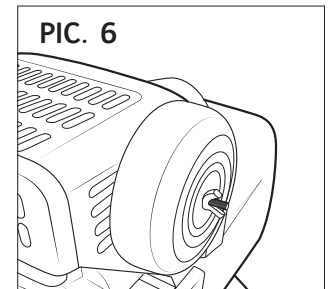



USING YOUR PRODUCT

POSITIONING YOUR NEW AIR COMPRESSOR

Always position air compressor on level ground.

Always position air compressor away from work area so that the air compressor does not get covered in dust, water or paint.

RUNNING IN YOUR NEW AIR COMPRESSOR

Your new air compressor requires running in.

1. Plug the power cord into a standard 230-240V AC 50Hz power point.
2. Open the tank drain tap.
3. Start the air compressor using the ON / OFF button.
4. Run the air compressor for approximately 1 minute.

This ensures that the air compressor is fully lubricated under no load.

After the 1 minute stop the air compressor using the ON / OFF button. Allow to cool approximately 5 minutes. Recheck the oil level and top up if needed.

Before starting your air compressor again ensure tank drain tap is closed.



WARNING! BEFORE RUNNING IN ENSURE THAT THE FOLLOWING HAS BEEN COMPLETED: THE OIL BREATHER HAS BEEN FITTED, THE OIL LEVEL IS CORRECT AND THE AIR COMPRESSOR HAS BEEN FULLY ASSEMBLED.



WARNING! ALWAYS ENSURE THAT YOU PLUG YOUR AIR COMPRESSOR INTO A STANDARD 240V AC POWER POINT. NEVER USE AN EXTENSION CORD, USE A LONGER AIR HOSE IF YOU NEED TO GET CLOSER TO YOUR WORK AREA.

ADJUSTING THE PRESSURE

Pumping starts at (minimum) 90PSI and stops at (maximum) 115PSI. Once the initial pump up stage has finished you can adjust the outlet air pressure to the tool's recommended working pressure. Pic. 9.

To adjust the outlet air pressure, use the red coloured regulator knob and check the pressure on the outlet pressure gauge. If the pressure needs to be lower, turn anti clockwise. If the pressure needs to be higher, turn clockwise. Use the gauge to ensure you set the correct working pressure.

NOTE: Different air tools require different operating pressures. Always check with the tool manufacturer if unsure.

WHEN YOU'RE FINISHED

1. Turn your air compressor OFF, using the ON/OFF button.
2. Turn the power point OFF and disconnect the power lead.
3. Disconnect your air tools and air hose.
4. Clean your air hose and air tools.
5. Store your air hose and air tools in a secure well ventilated cabinet.
6. Slowly open the tank drain tap. This allows excess air and moisture, water, to vent.
7. Leave the tank drain tap open. This allows any moisture to drain while the air compressor is stored.

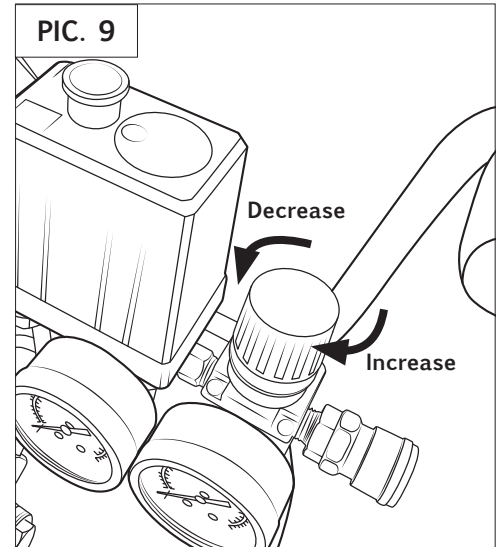

WARNING! ALWAYS TURN OFF AND UNPLUG FROM POWER POINT WHEN NOT IN USE OR WHEN UNATTENDED.



WARNING! THIS COMPRESSOR HAS A MAXIMUM PRESSURE OF 8 BAR. ALWAYS REGULATE THE OUTLET AIR PRESSURE TO MATCH YOUR AIR TOOL.

DIFFERENT AIR TOOLS REQUIRE DIFFERENT OPERATING PRESSURES. ALWAYS CHECK WITH THE AIR TOOL MANUFACTURER IF UNSURE.



DAILY: BEFORE USE

1. Check the oil level.
2. Seal the tank drain tap.

AFTER USE

1. Disconnect from main power.
2. Open the tank drain tap.
3. Wipe down the air compressor.
4. Store safely and securely.

EVERY 50 HOURS

1. Replace the air filter.
2. Drain oil completely and replace with fresh oil.

TO DRAIN OIL

1. Loosen and remove the drain bolt and drain oil into a funnel / bottle and dispose of in an appropriate manner.
2. Once drained, replace and tighten the drain bolt.
3. Wipe up any oil spills.
4. Fill up to the top red dot on the sight glass with fresh clean oil.

NOTE: Use oil type SAE30.

DRAIN TAP

After use, slowly open the drain tap to drain excess air and any moisture. The excess air will also help purge the moisture. Leave the drain tap open when air compressor is not in use, so any moisture can continue to drain.

To open the drain tap pull the lever down to vertical. Pic. 10.

To seal the drain tap push the lever up to horizontal. Pic. 11.

NOTE: Remember to seal the drain tap before starting the air compressor.

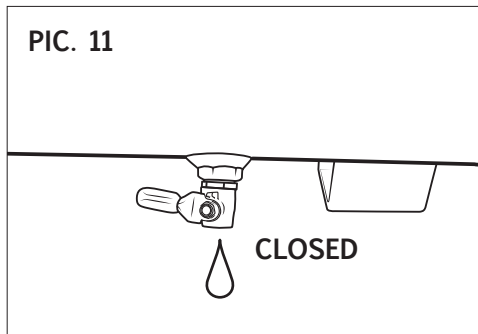
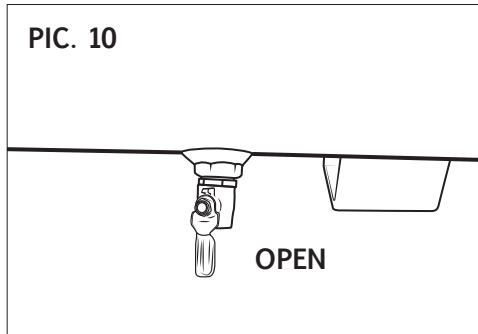

AIR FITTING OUTLET

This air compressor is fitted with a 'Nitto style' (female) socket. Pic. 12.

1. Slide the outer collar backwards.
2. Push in the 'Nitto style' male plug (not included).
3. Release the collar.
4. Fully and completely push the 'Nitto style' male plug (not included) into the 'Nitto style' female socket until it clicks and outer collar moves forward.

Note: This air compressor has a maximum pressure of 8 bar. Always regulate the air pressure to match your air tool. Different air tools require different operating pressures. Always check with the tool manufacturer if unsure.

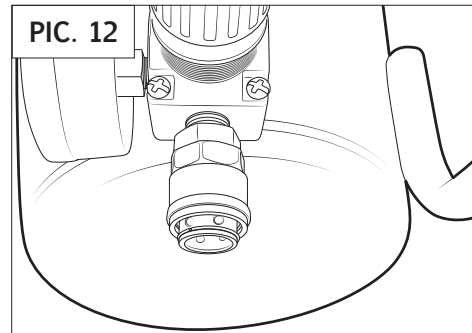



TROUBLESHOOTING

IF YOUR AIR COMPRESSOR DOES NOT START

- Check that you have plugged the power lead into a standard 240V 10Amp power point and turned the switch ON.
- Check that you have turned on the air compressor by lifting the ON/OFF button UP.
- The air tank may be full. Use your air tool and the air compressor should start when the pressure decreases to 90PSI.

IF YOUR AIR COMPRESSOR DOES NOT BUILD UP PRESSURE

- Check that the tank drain tap is sealed.
- Air filter could be dirty or blocked, replace air filter.

IF YOUR AIR COMPRESSOR DOES NOT HOLD PRESSURE

- Check your hose and tool for leaks and fix as appropriate.
- Check that drain valve is sealed.
- Check Nitto style fitting with soapy water mix and if bubbles then call Smart Marketing Group for options.

IF YOUR AIR COMPRESSOR SMELLS LIKE BURNT OIL

- Check the oil level as it may be low.

If these tips do not work please have your unit checked by an authorised service centre.

Call Smart Marketing Group Pty. Ltd. for your closest centre:

AUSTRALIA: 1300 660 457 NEW ZEALAND: 0800 474 876

SPECIFIC SAFETY INSTRUCTIONS

IMPORTANT

This air compressor is fitted with a sealed electrical connection plug that is compatible with the mains power supply for Australia / New Zealand and meets the requirements of Australian Standards. This air compressor must be connected to a supply voltage that is equal to that stated on the rating label. If the mains power connection plug or power cord becomes damaged it must be replaced with a complete assembly that is identical to the original, and this must be replaced by an authorised service facility. Always follow the Australian / New Zealand requirements for connection to the mains supply. If in doubt always consult a qualified electrician.



WARNING! DO NOT USE THE AIR COMPRESSOR IN AREAS WHERE THERE IS A RISK OF EXPLOSION OR FIRE FROM COMBUSTIBLE MATERIALS. THE SPARKS GENERATED FROM CERTAIN TOOLS ATTACHED TO AIR COMPRESSOR CAN IGNITE COMBUSTIBLE MATERIALS AS WELL AS FLAMMABLE LIQUIDS, PAINT, VARNISH, PETROL, FLAMMABLE GASES AND DUST OF AN EXPLOSIVE NATURE. AS A PRECAUTION IT IS RECOMMENDED THAT YOU CONSULT AN EXPERT ON A SUITABLE FIRE EXTINGUISHER AND ITS USE.

- Initially remove the transport plug and replace with the oil breather BEFORE using the first time
- Do not attempt to modify the air compressor, guards or the supplied accessories in any way.
- Domestic air compressors are designed for intermittent operation. Ideally a 75% duty cycle. (Meaning: 45 seconds ON motor pumping and 15 seconds OFF, motor not pumping). Simply put, when the motor is pumping, the attached air tool can not be used. Only use the attached air tool while the compressor is not pumping.
- Stop using the attached tool as soon as the air compressor starts pumping.
- Always check the oil level before use. The oil level should be to the top of the red dot on the sight glass.
- Fully assemble air compressor before use.
- Always ensure your air compressor is level and stable.

- Never run this air compressor without the wheels and/or rubber stopper(s) being correctly fitted.
- Never use an extension cord with this air compressor always use a longer air hose.
- Never connect to a generator which does not produce sufficient power, at least 3500W and has pure sine wave power output.
- Domestic air compressors are not designed for industrial /commercial applications.
- Domestic air compressors are not designed for continuous running. Always follow duty cycle - 75%.
- Avoid touching the pump area as it can become very hot and may burn.
- Ensure that the air compressor is disconnected from the mains supply when not in use, before lubricating servicing, making changes and when changing attachments such as air hoses / tools.
- Always use the correct type of tool for the operation to be carried out.
- Never use the air compressor if any part of the unit is damaged. Always have the air compressor serviced by an authorised service facility.
- Always wear safety eye, ear and respiratory protection when operating the air compressor.
- Allow the tank to completely fill before using the air compressor.
- If the air compressor makes an unfamiliar sound or vibrates excessively, switch the air compressor 'OFF' immediately and disconnect from the mains power supply. Investigate the possible cause or consult your authorised service facility.
- Always move the air compressor using the handle and wheels.
- Always use the air compressor on stable ground.
- This air compressor is designed to compress normal air. Never use to compress any other type(s) of gases.
- Never direct the jet of air or other liquids / gases towards your body, other persons or animals.
- Never direct the jet of air or other liquids / gases towards this air compressor.
- This air compressor is not suitable for pharmaceutical, food or sanitary purposes.
- This air compressor is not to be used to for filling scuba or oxygen air bottles or tanks.
- Always follow the instructions relating to the tools attached to this air compressor.
- Do not use an extension lead plug air compressor power lead directly into power point.
- Always turn off and unplug from power point when not in use or when unattended.

LUBRICATION OF AIR COMPRESSOR

Before attempting to operate this air compressor the transport plug must be removed, thrown out and replaced with the oil breather. Check the oil level to ensure the level is to the top of the red dot on the sight glass; refer to page 5 for complete details and diagram. Failure to do these may result in damage to the air compressor and / or injury to the user.

PLEASE follow the instructions noted on page 5 on changing the transport plug to the oil breather.

ASSEMBLY

This air compressor MUST be fully assembled by you prior to use. Failure to do so will result in the warranty being VOID. Failure to fully assemble this air compressor may also result in personal injury.

SAFETY

Before attempting to operate this air compressor the following basic safety precautions should be taken to reduce the risk of fire, electric shock and personal injury. It is important to read the instruction manual and to understand applications, limitations and potential hazards associated with the air compressor. This air compressor is not intended for use by persons (including children) with reduced physical, sensory or mental capabilities, or lack of experience and knowledge, unless they have been given supervision or instruction concerning the use of the appliance by a person responsible for their safety.

BEWARE OF CHILDREN AND PETS

Children and pets should be kept out of the work area. Children should not be allowed to touch or operate the air compressor, tools or extension cords. This air compressor is not designed for use by young children or infirm persons without supervision. The air compressor and tools should be kept out of reach of children, preferably stored or locked in a secure cabinet or room when not in use. Children should be supervised to ensure that they do not play with the appliance.

WORK AREA

Work areas and benches should be kept tidy. Cluttered benches and work areas can cause



accidents. Floors should be kept clean and free from rubbish. Special care should be taken when the floor is slippery due to sawdust or wax. Always leave sufficient distance, at least 5 metres between the air compressor and the work area, especially when using tools designed for sanding or spraying liquids.

WORK ENVIRONMENT

Do not expose your air compressor to rain, or use in damp or wet conditions. Keep the work area well lit. Always ensure your air compressor is level and stable. Using your air compressor on unlevel or unstable ground may cause a lack of lubrication and the pump to seize, this damage will not be covered under warranty.

GUARD AGAINST ELECTRIC SHOCK

Avoid body contact with earthed or grounded surfaces (e.g. pipes and refrigerators).

DO NOT FORCE AIR COMPRESSORS

The air compressor will do a better, safer job and give you much better service life, if it's used at the duty cycle for which it was designed. The duty cycle will only take effect after the initial (1st) tank fill for the day. This air compressors duty cycle is 75%. Duty cycle is the proportion of time during which the air compressor is operating compared with not operating. For example a 75% duty cycle could mean after 45 seconds of operation, motor pumping, the air compressor must be left for 15 seconds resting, motor not pumping. When the motor is pumping the attached air tool can not be used. Simple way to understand duty cycle is only use the attached air tool while the air compressor is not pumping. Stop using the attached tool as soon as the air compressor starts pumping.

USE THE RIGHT TOOL

Select the right tool for the job. Do not use a tool for a job for which it was not designed. Do not force a small air compressor to do the job of a heavy-duty air compressor. Do not use the air compressor for purposes not intended.

DO NOT ABUSE POWER CORD

Never yank or pull on the power cord to disconnect it from the mains supply socket. Never carry or pull your air compressor by its power cord. Keep the power cord away from heat, oil, solvents and sharp edges. Regularly check the plug and cord. If the supply cord is damaged, it must be replaced by the manufacturer, its service agent or similarly qualified persons in order to avoid a hazard.

EXTENSION CORDS AND REELS

This air compressor MUST be plugged directly into a 240V AC wall socket. This air compressor is NOT designed to be run off an extension cord/lead. If you need extra distance do NOT use an extension cord, USE A LONGER AIR HOSE. The use of extension cords may cause power voltage loss and will result in damage to the motor. This will NOT be covered under warranty.

SECURE THE WORK PIECE

Whenever possible secure the work piece using clamps or a vice. It is safer than using your hands or feet and leaves both hands free to control the tool.

HOT COMPONENTS

Beware many of the components will get hot during use. Never touch any of the metal pipes, pump or motor as these may burn.

MAINTAIN YOUR AIR COMPRESSOR WITH CARE

Follow the instructions for lubricating and changing accessories. Check the air compressor power cord periodically and if damaged, have it replaced by an authorised service facility. Keep

PERSONAL SAFETY

CLOTHING

Do not wear loose clothing, jewellery or anything that could get caught in moving machinery.

HAIR

Long hair should be tied back or contained in a protective covering.

EYE PROTECTION

The use of safety goggles is highly recommended (normal glasses are not sufficient for eye protection) when using an air compressor. Prescription glasses do not have safety lenses.

FOOTWEAR

Where there is the risk of heavy objects or if there is a risk of slipping on wet or slippery floors, suitable non-slip safety footwear should be worn. Protect your feet from dropping accidents.

EAR PROTECTION

The use of ear protection is highly recommended when using air compressors. The continual noise may damage your ears.

RESPIRATORY PROTECTION

When operating any machinery that creates dust, or when spray painting, an approved dust / filter mask must be worn. When machining concrete, man made fibres, especially MDF (Medium Density Fibre board), the resin used in these materials can be hazardous to your health. Use an approved face mask with replaceable filter.

DO NOT OVER REACH

Do not over reach. Keep a proper footing and maintain your balance at all times. Avoid using abnormal stances and awkward body positions.

STAY ALERT

Watch what you are doing, use common sense and never operate an air compressor under the influence, when you are tired, drinking alcohol, taking drugs or if taking medication that causes drowsiness.

handles clean, dry and free from oil and grease. Ensure that ventilation slots are kept clean and free from dust at all times. Blocked ventilation slots or air filter can cause overheating and damage to the motor and this will not be covered under warranty.

DISCONNECT AIR COMPRESSOR

Ensure that the air compressor is disconnected from the mains supply when not in use, before servicing, lubricating, making adjustments or when changing any accessories.

REMOVE ADJUSTING KEYS AND WRENCHES

Form the habit of always checking to see that any adjusting keys or wrenches have been removed from the air compressor or attached air tools before operating.

AVOID UNINTENTIONAL STARTING

Ensure that the ON/OFF button is in the 'OFF' position (Push Button Down) before plugging the air compressor into the mains supply.

Always turn off and unplug from power point when not in use or when unattended.

PROTECT FURNISHINGS

If using the air compressor inside your house, protect furnishings and floors with a suitable dust sheet.

FIRE PRECAUTIONS

When using the air compressor inside your house or workshop general fire precautions should be observed. As a precaution it is recommended that an expert is consulted on obtaining and using a suitable fire extinguisher.

CLEANING YOUR AIR COMPRESSOR

Always disconnect your air compressor from the mains power supply before you commence cleaning. Always ensure that your air compressor has cooled, about one (1) hour, before cleaning and storing. When cleaning your air compressor use only a damp soft cloth. NEVER use liquid or solvents of any type.



Thank you for choosing this product. We stand behind the quality of our range. Please submit claims online at: www.smga.com.au/pages/support

Please **keep your purchase** receipt (bank statements are not accepted). Your receipt is required for any warranty claim. A photo or a copy of your receipt is acceptable providing all information is legible.

Our products are guaranteed to be free from defects in materials and workmanship for 2 years from the date of purchase.

If a manufacturing fault occurs during this period, SMG will repair or replace the product (or part) at no cost to you.

WHAT'S COVERED

Your SMG product is covered against **defects in materials and workmanship**.

- If a manufacturing fault is confirmed, we'll **repair or replace** the faulty part or product **free of charge**.
- Replacement parts may be **new or refurbished** but will always be of equal quality.

WHAT'S NOT COVERED

This warranty does not cover:

- Use for **hire or commercial purposes**.
- Damage from **misuse, neglect, incorrect installation**, or failure to follow instructions.
- **Rust, corrosion, dust, dirt, insect or spider blockages**.
- **Third-party or non-SMG accessories**.
- Normal wear and tear, servicing, or maintenance items.
- Freight costs if the product is **found fault-free**.
- Repair costs if the product is **found fault-free**.

HOW TO MAKE A CLAIM

1. Please submit claims online at: www.smga.com.au/pages/support
2. Empty any oil or fuel before returning
3. Send the product **securely packaged** if required.
4. If the product is faulty, repairs are **free of charge**.
5. If no fault is found, **service and freight charges** will apply.

YOUR RIGHTS

Australia

Our goods come with guarantees that cannot be excluded under the Australian Consumer Law. You are entitled to a replacement or refund for a major failure and compensation for any other reasonably foreseeable loss or damage. You are also entitled to have the goods repaired or replaced if the goods fail to be of acceptable quality and the failure does not amount to a major failure.

New Zealand

This warranty is in addition to your rights under the New Zealand Consumer Guarantees Act 1993.

NEED HELP?

For assistance, or if you cannot access our online form:

AUSTRALIA: 1300 660 457

NEW ZEALAND: 0800 474 876

Email: service.group@smga.com.au

Smart Marketing Group Pty Ltd

33-35 Lionel Road, Mt Waverley, VIC 3149, Australia

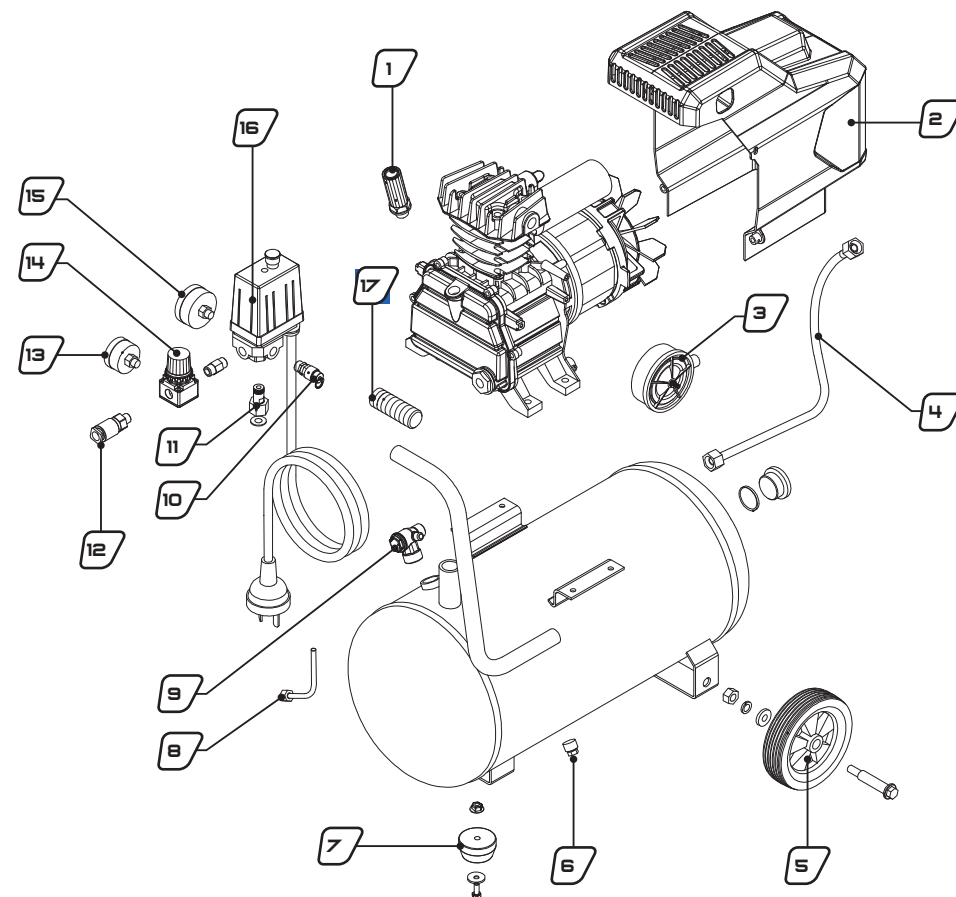

No.	Description	Qty	Part No.
1	Oil Breather	1	95 BROB
2	Motor Cover	1	95 BRMC
3	Air Filter	1	95 BRAF
4	Exhaust Tube	1	95 BRET
5	Wheel and Cap	2	95 BRWHC
6	Drain Tap	1	95 BRDT
7	Cushion Foot	1	95 BRRS
8	Unloading Tube	1	95 BRUT
9	One Way Valve	1	95 BROWV

No.	Description	Qty	Part No.
10	Safety Valve	1	95 BRSPV
11	Connector	1	95 BRPTC
12	Outlet Fitting	1	95 BROFN
13	Pressure Gauge - Outlet	1	95 BRPG
14	Regulator - Single Outlet	1	95 BRRSO
15	Pressure Gauge - Tank	1	95 BRPG
16	Pressure Switch	1	95 BRPS
17	Rubber Handle Grip	1	95 BRTHG

ToolPRO

Air

PLU: 723464
CODE: TP1000

Manufactured and Packaged for
SRGS PTY. LTD. ABN 23 113 230 050
6 Coulthards Avenue, Strathpine,
Queensland 4500, Australia.

Made in China