

# ToolPRO

**2 YEAR**  
WARRANTY

## Air



# 1.25HP

SILENCED AIR COMPRESSOR

INSTRUCTION MANUAL

PLU: 723466



For service, spare parts or product information,  
please contact: Smart Marketing Group Pty. Ltd

**AUSTRALIA: 1300 660 457**  
**NEW ZEALAND: 0800 474 876**

AIR COMPRESSOR

**TP500Q**

VOLTAGE

**230-240V AC - 50HZ**

MOTOR

**ELECTRIC 1.25HP**

WATTAGE

**900W**

NO LOAD SPEED

**2800RPM**

FREE AIR DELIVERY (FAD)

**75L PER MINUTE**

TANK SIZE

**6L**

DUTY CYCLE

**75%**

MAX. TANK PRESSURE

**115PSI (8 BAR)**

OUTLET PRESSURE

**0PSI - 115PSI ADJUSTABLE**

OIL TYPE

**OIL FREE- NO LUBRICATION REQUIRED**

NOISE RATING

**61DB@5M LWA@1DB**

MOTOR / PUMP KICKS IN

**87PSI**

PRESSURE CYCLE STOPS

**115PSI**

NUMBER OF OUTLETS

**1**

## 1.25HP SILENCED AIR COMPRESSOR MODEL NO. TP500Q

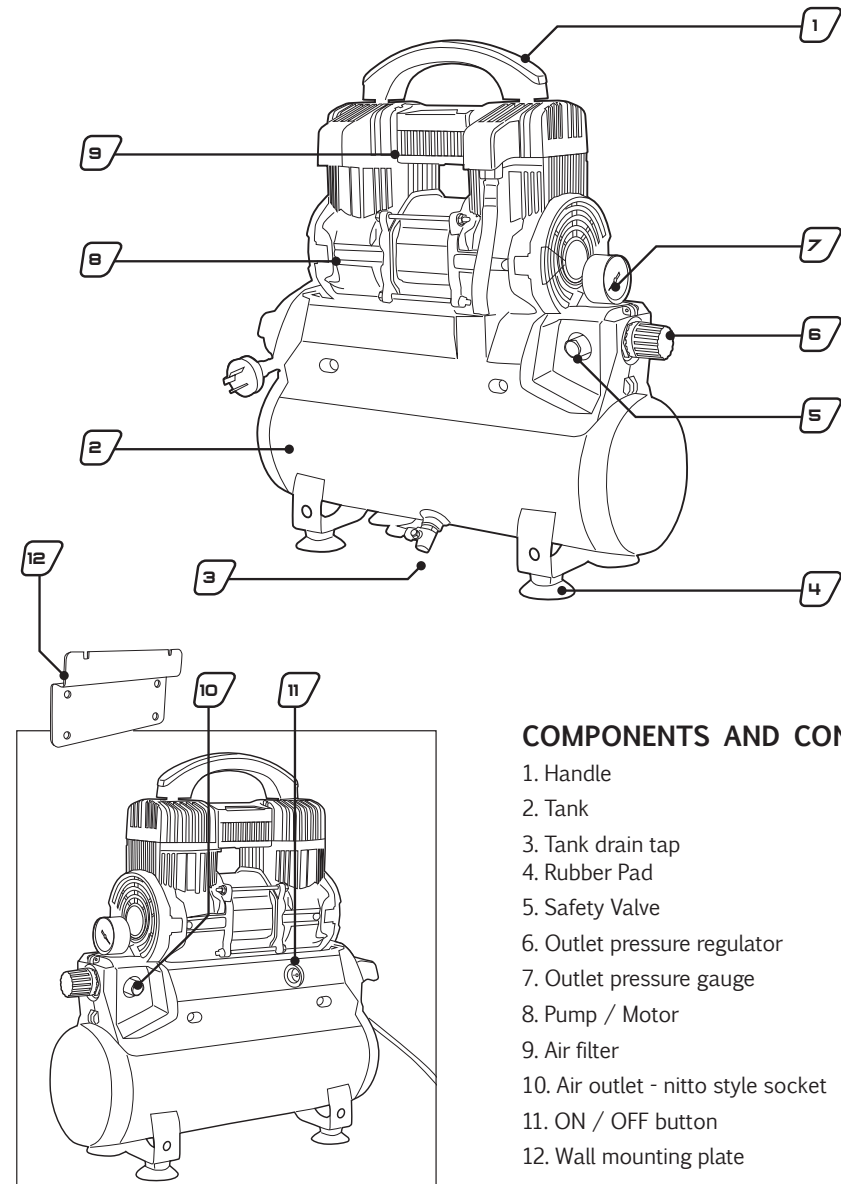

### COMPONENTS AND CONTROLS

1. Handle
2. Tank
3. Tank drain tap
4. Rubber Pad
5. Safety Valve
6. Outlet pressure regulator
7. Outlet pressure gauge
8. Pump / Motor
9. Air filter
10. Air outlet - nitto style socket
11. ON / OFF button
12. Wall mounting plate



Before using air compressor it should be carefully checked to determine that it will operate properly and perform its intended function.

- Check for broken or missing parts.
- The air compressor should be set up near to the user.
- Check any other condition that may affect the operation of the air compressor.
- Before you use your air compressor, make sure that the mains voltage complies with the specifications on the rating plate.
- A guard or any other part of the air compressor that is damaged should be properly repaired or replaced by an authorised service facility unless otherwise indicated in this instruction manual.

**WARNING!** ENSURE THE AIR COMPRESSOR IS TURNED OFF AND DISCONNECTED FROM THE POWER SUPPLY BEFORE PERFORMING ANY OF THE FOLLOWING OPERATIONS. ALWAYS KEEP THE AIR COMPRESSOR UPRIGHT.

## ASSEMBLY UNPACKING

Carefully unpack your air compressor. This air compressor is bulky and heavy, two (2) person lift may be required. Dispose of all packing material in an environmentally responsible manner.

## RUBBER STOPPER

For this air compressor, the rubber stoppers are already assembled.

## HANDLE INSTALLATION

Attach the handle to the compressor unit with the supplied screws, then clip the outer handle cover to the main handle. Pic 1.

## WALL MOUNTING

This air compressor comes with a wall mounting bracket should you wish to attach it to a wall. Suitable masonry anchors (not supplied) should be used when attaching the bracket to a masonry wall. Please note, the compressor is heavy. **Do not mount it onto a plaster wall.** Once wall bracket is secured to a wall, the compressor unit can be hooked onto the bracket. Please note it must be groove-to-groove, as picture 2 shows, to avoid unexpected movement when operating.

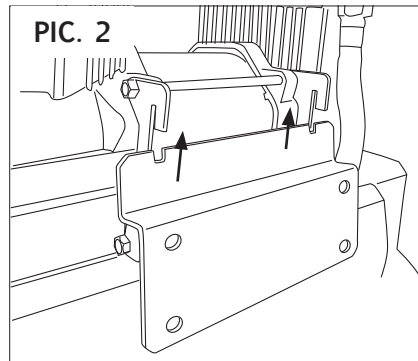
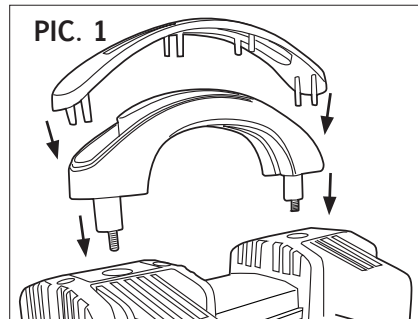

## TO TURN YOUR AIR COMPRESSOR ON

Push down the '1'

## TO TURN YOUR AIR COMPRESSOR OFF

Push down the '0'

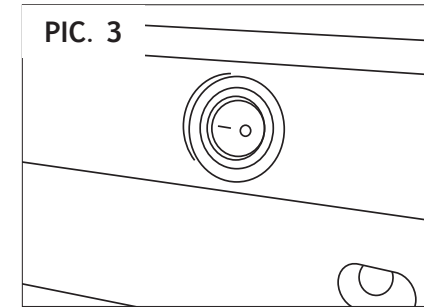

## USING YOUR PRODUCT

### RUNNING IN YOUR NEW AIR COMPRESSOR

Your new oil free air compressor does not require any running in.

### COLD WEATHER STARTING

If the ambient temperature has dropped below 10°C your air compressor may struggle to start. To ensure your air compressor starts smoothly we recommend starting your air compressor in the following way when cold, for the first time.

1. Open drain tap and drain air completely.
2. Leave drain tap open.
3. Start air compressor, following the steps from section "STARTING THE AIR COMPRESSOR", steps 3 through 5.
4. Allow your air compressor to run with drain tap open for about 30 seconds to a minute.
5. Close drain tap.
6. Continue to follow steps from section "STARTING THE AIR COMPRESSOR", steps 6 through 8.
7. Your air compressor will continue to operate correctly.

**WARNING!** BEFORE USING ENSURE THAT THE FOLLOWING HAS BEEN COMPLETED:

- AIR COMPRESSOR FULLY ASSEMBLED
- AIR COMPRESSOR LEVEL

**WARNING!** ALWAYS ENSURE THAT YOU PLUG YOUR AIR COMPRESSOR INTO A STANDARD 240V AC POWER POINT. NEVER USE AN EXTENSION CORD, USE A LONGER AIR HOSE IF YOU NEED TO GET CLOSER TO YOUR WORK AREA.



## STARTING THE AIR COMPRESSOR

Before starting run through this simple list;

1. Fully assembled.
2. Drain tap – close fully.
3. Check power lead for any damage. If damaged have replaced by an authorised service centre.
4. Plug compressor into a standard 240V 10Amp AC power point and turn ON.
5. Switch on the air compressor, Pic 3.
6. Allow the compressor to fill the air tank.
7. Connect your air hose and air tools.
8. Once turned on and you begin using the connected air tools the compressor will start and stop without warning. This is controlled by the pressure switch. These pressure settings are factory set and should not be changed.

NOTE: Pumping starts at (minimum) 87PSI and stops at (maximum) 115PSI. Once the initial pump up stage has finished you can use the compressor.

This compressor has a maximum pressure of 8 bar. Always regulate the outlet air pressure to match your air tool.

Different air tools require different operating pressures. Always check with the air tool manufacturer if unsure.

## ADJUSTING THE PRESSURE

Pumping starts at (minimum) 87PSI and stops at (maximum) 115PSI. Once the initial pump up stage has finished you can adjust the outlet air pressure to the tool's recommended working pressure. Pic. 4.

To adjust the outlet air pressure, use the red coloured regulator knob and check the pressure on the outlet pressure gauge. If the pressure needs to be lower, turn anti clockwise. If the pressure needs to be higher, turn clockwise. Use the gauge to ensure you set the correct working pressure.

NOTE: Different air tools require different operating pressures. Always check with the tool manufacturer if unsure.

## WHEN YOU'RE FINISHED

1. Turn your air compressor OFF, using the ON/OFF button.
2. Turn the power point OFF and disconnect the power lead.
3. Disconnect your air tools and air hose.
4. Clean your air hose and air tools.
5. Store your air hose and air tools in a secure well ventilated cabinet.
6. Slowly open the tank drain tap. This allows excess air and moisture, water, to vent.
7. Leave the tank drain tap open. This allows any moisture to drain while the air compressor is stored.

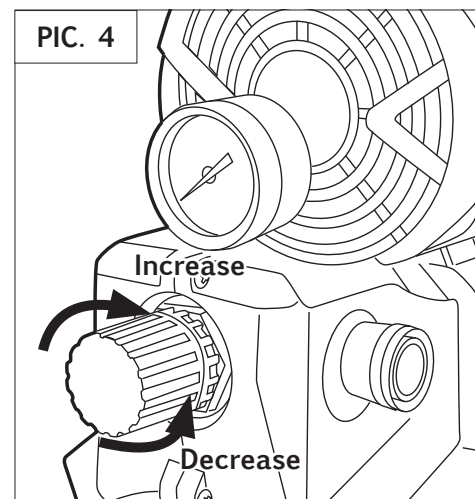

**WARNING!** ALWAYS TURN OFF AND UNPLUG FROM POWER POINT WHEN NOT IN USE OR WHEN UNATTENDED.

**WARNING!** THIS COMPRESSOR HAS A MAXIMUM PRESSURE OF 8 BAR. ALWAYS REGULATE THE OUTLET AIR PRESSURE TO MATCH YOUR AIR TOOL.  
DIFFERENT AIR TOOLS REQUIRE DIFFERENT OPERATING PRESSURES. ALWAYS CHECK WITH THE AIR TOOL MANUFACTURER IF UNSURE.



## DAILY: BEFORE USE

1. Seal the tank drain tap.

## AFTER USE

1. Disconnect from main power.
2. Open the tank drain tap.
3. Wipe down the air compressor.
4. Store safely and securely.

## EVERY 50 HOURS

1. Replace the air filter.

## DRAIN TAP

After use, slowly open the drain tap to drain excess air and any moisture. The excess air will also help purge the moisture. Leave the drain tap open when air compressor is not in use, so any moisture can continue to drain.

To open the drain tap pull the lever down to vertical. Pic. 5.

To seal the drain tap push the lever up to horizontal. Pic. 6.

NOTE: Remember to seal the drain tap before starting the air compressor.

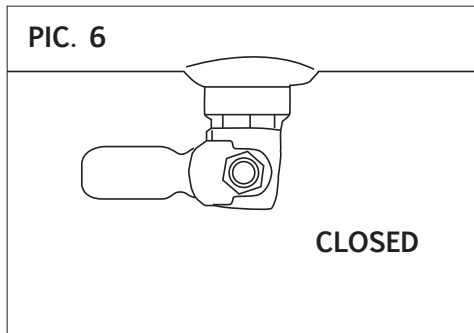
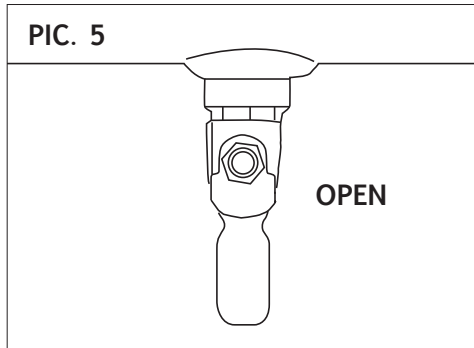

## AIR FITTING OUTLET

This air compressor is fitted with a 'Nitto style' (female) socket. Pic. 7.

1. Slide the outer collar backwards.
2. Push in the 'Nitto style' male plug (not included).
3. Release the collar.
4. Fully and completely push the 'Nitto style' male plug (not included) into the 'Nitto style' female socket until it clicks and outer collar moves forward.

Note: This air compressor has a maximum pressure of 8 bar. Always regulate the air pressure to match your air tool. Different air tools require different operating pressures. Always check with the tool manufacturer if unsure.

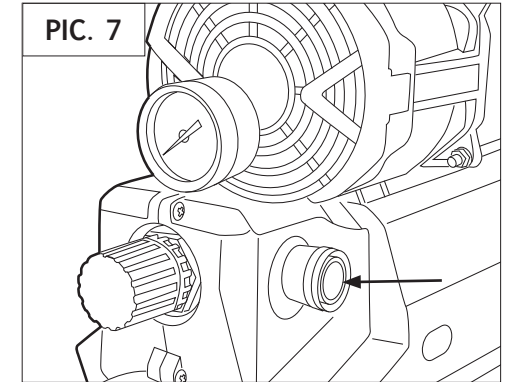

## REPLACING AIR FILTER

The air filter can be replaced by removing the screws that hold the bottom tray of the air filter case. Pic.8.

Take out the used air filter, replace with a new one (when necessary). Slide the bottom tray back to its original position, then hand tighten the screws. Pic.9.

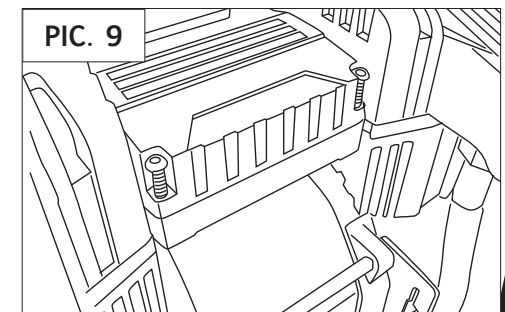
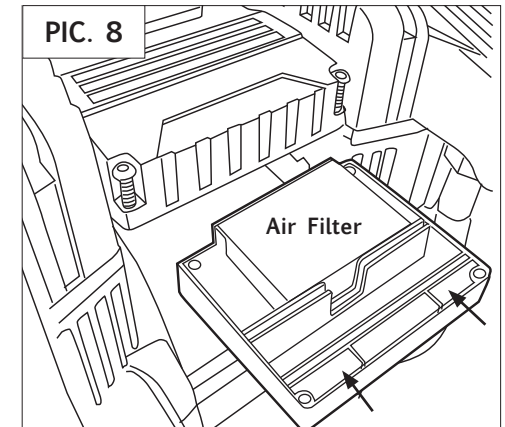



## TROUBLESHOOTING

### IF YOUR AIR COMPRESSOR DOES NOT START

- Check that you have plugged the power lead into a standard 240V 10Amp power point and turned the switch ON.
- Check that you have turned on the air compressor by lifting the ON/OFF button UP.
- The air tank may be full. Use your air tool and the air compressor should start when the pressure decreases to 87PSI.

### IF YOUR AIR COMPRESSOR DOES NOT BUILD UP PRESSURE

- Check that the tank drain tap is sealed.
- Air filter could be dirty or blocked, replace air filter.

### IF YOUR AIR COMPRESSOR DOES NOT HOLD PRESSURE

- Check your hose and tool for leaks and fix as appropriate.
- Check that drain valve is sealed.
- Check Nitto style fitting with soapy water mix and if bubbles then call Smart Marketing Group for options.

If these tips do not work please have your unit checked by an authorised service centre. Call Smart Marketing Group Pty. Ltd. for your closest centre:

**AUSTRALIA: 1300 660 457**  
**NEW ZEALAND: 0800 474 876**

## SPECIFIC SAFETY INSTRUCTIONS

### IMPORTANT

This air compressor is fitted with a sealed electrical connection plug that is compatible with the mains power supply for Australia / New Zealand and meets the requirements of Australian Standards. This air compressor must be connected to a supply voltage that is equal to that stated on the rating label. If the mains power connection plug or power cord becomes damaged it must be replaced with a complete assembly that is identical to the original, and this must be replaced by an authorised service facility. Always follow the Australian / New Zealand requirements for connection to the mains supply. If in doubt always consult a qualified electrician.



**WARNING! DO NOT USE THE AIR COMPRESSOR IN AREAS WHERE THERE IS A RISK OF EXPLOSION OR FIRE FROM COMBUSTIBLE MATERIALS. THE SPARKS GENERATED FROM CERTAIN TOOLS ATTACHED TO AIR COMPRESSOR CAN IGNITE COMBUSTIBLE MATERIALS AS WELL AS FLAMMABLE LIQUIDS, PAINT, VARNISH, PETROL, FLAMMABLE GASES AND DUST OF AN EXPLOSIVE NATURE. AS A PRECAUTION IT IS RECOMMENDED THAT YOU CONSULT AN EXPERT ON A SUITABLE FIRE EXTINGUISHER AND ITS USE.**

- Do not attempt to modify the air compressor, guards or the supplied accessories in any way.
- Domestic air compressors are designed for intermittent operation. Ideally a 75% duty cycle. (Meaning: 45 seconds ON motor pumping and 15 seconds OFF, motor not pumping). Simply put, when the motor is pumping, the attached air tool can not be used. Only use the attached air tool while the compressor is not pumping.
- Stop using the attached tool as soon as the air compressor starts pumping.
- Fully assemble air compressor before use.
- Always ensure your air compressor is level and stable.
- Never run this air compressor without the wheels and/or rubber stopper(s) being correctly fitted.
- Never use an extension cord with this air compressor always use a longer air hose.

- Never connect to a generator which does not produce sufficient power, at least 3500W and has pure sine wave power output.
- Domestic air compressors are not designed for industrial /commercial applications.
- Domestic air compressors are not designed for continuous running. Always follow duty cycle - 75%.
- Avoid touching the pump area as it can become very hot and may burn.
- Ensure that the air compressor is disconnected from the mains supply when not in use, before servicing, making changes and when changing attachments such as air hoses / tools.
- Always use the correct type of tool for the operation to be carried out.
- Never use the air compressor if any part of the unit is damaged. Always have the air compressor serviced by an authorised service facility.
- Always wear safety eye, ear and respiratory protection when operating the air compressor.
- Allow the tank to completely fill before using the air compressor.
- If the air compressor makes an unfamiliar sound or vibrates excessively, switch the air compressor 'OFF' immediately and disconnect from the mains power supply. Investigate the possible cause or consult your authorised service facility.
- Always move the air compressor using the handle and wheels.
- Always use the air compressor on stable ground.
- This air compressor is designed to compress normal air. Never use to compress any other type(s) of gases.
- Never direct the jet of air or other liquids / gases towards your body, other persons or animals.
- Never direct the jet of air or other liquids / gases towards this air compressor.
- This air compressor is not suitable for pharmaceutical, food or sanitary purposes.
- This air compressor is not to be used to fill scuba or oxygen air bottles or tanks.
- Always follow the instructions relating to the tools attached to this air compressor.
- Do not use an extension lead plug air compressor power lead directly into power point.
- Always turn off and unplug from power point when not in use or when unattended.

## LUBRICATION OF AIR COMPRESSOR

This compressor is OIL FREE. Therefore there is NO oil used for lubrication.

## ASSEMBLY

This air compressor MUST be fully assembled by you prior to use. Failure to do so will result in the warranty being VOID. Failure to fully assemble this air compressor may also result in personal injury.

## SAFETY

Before attempting to operate this air compressor the following basic safety precautions should be taken to reduce the risk of fire, electric shock and personal injury. It is important to read the instruction manual and to understand applications, limitations and potential hazards associated with the air compressor. This air compressor is not intended for use by persons (including children) with reduced physical, sensory or mental capabilities, or lack of experience and knowledge, unless they have been given supervision or instruction concerning the use of the appliance by a person responsible for their safety.

## BEWARE OF CHILDREN AND PETS

Children and pets should be kept out of the work area. Children should not be allowed to touch or operate the air compressor, tools or extension cords. This air compressor is not designed for use by young children or infirm persons without supervision. The air compressor and tools should be kept out of reach of children, preferably stored or locked in a secure cabinet or room when not in use. Children should be supervised to ensure that they do not play with the appliance.

## WORK AREA

Work areas and benches should be kept tidy. Cluttered benches and work areas can cause accidents. Floors should be kept clean and free from rubbish. Special care should be taken when the floor is slippery due to sawdust or wax. Always leave sufficient distance, at least 5 metres between the air compressor and the work area, especially when using tools designed for sanding or spraying liquids.



## WORK ENVIRONMENT

Do not expose your air compressor to rain, or use in damp or wet conditions. Keep the work area well lit. Always ensure your air compressor is level and stable. Using your air compressor on unlevel or unstable ground may cause a lack of lubrication and the pump to seize, this damage will not be covered under warranty.

## GUARD AGAINST ELECTRIC SHOCK

Avoid body contact with earthed or grounded surfaces (e.g. pipes and refrigerators).

## DO NOT FORCE AIR COMPRESSORS

The air compressor will do a better, safer job and give you much better service life, if it's used at the duty cycle for which it was designed. The duty cycle will only take effect after the initial (1st ) tank fill for the day. This air compressors duty cycle is 75%. Duty cycle is the proportion of time during which the air compressor is operating compared with not operating. For example a 75% duty cycle could mean after 45 seconds of operation, motor pumping, the air compressor must be left for 15 seconds resting, motor not pumping. When the motor is pumping the attached air tool can not be used. Simple way to understand duty cycle is only use the attached air tool while the air compressor is not pumping. Stop using the attached tool as soon as the air compressor starts pumping.

## USE THE RIGHT TOOL

Select the right tool for the job. Do not use a tool for a job for which it was not designed. Do not force a small air compressor to do the job of a heavy-duty air compressor. Do not use the air compressor for purposes not intended.

## DO NOT ABUSE POWER CORD

Never yank or pull on the power cord to disconnect it from the mains supply socket. Never carry or pull your air compressor by its power cord. Keep the power cord away from heat, oil, solvents and sharp edges. Regularly check the plug and cord. If the supply cord is damaged, it must be replaced by the manufacturer, its service agent or similarly qualified persons in order to avoid a hazard.

## EXTENSION CORDS AND REELS

This air compressor MUST be plugged directly into a 240V AC wall socket. This air compressor is NOT designed to be run off an extension cord/lead. If you need extra distance do NOT use an extension cord, USE A LONGER AIR HOSE. The use of extension cords may cause power voltage loss and will result in damage to the motor. This will NOT be covered under warranty.

## SECURE THE WORK PIECE

Whenever possible secure the work piece using clamps or a vice. It is safer than using your hands or feet and leaves both hands free to control the tool.

## HOT COMPONENTS

Beware many of the components will get hot during use. Never touch any of the metal pipes, pump or motor as these may burn.

## MAINTAIN YOUR AIR COMPRESSOR WITH CARE

Follow the instructions for lubricating and changing accessories. Check the air compressor power cord periodically and if damaged, have it replaced by an authorised service facility. Keep handles clean, dry and free from oil and grease. Ensure that ventilation slots are kept clean and free from dust at all times. Blocked ventilation slots or air filter can cause overheating and damage to the motor and this will not be covered under warranty.

## PERSONAL SAFETY

### CLOTHING

Do not wear loose clothing, jewellery or anything that could get caught in moving machinery.

### HAIR

Long hair should be tied back or contained in a protective covering.

### EYE PROTECTION

The use of safety goggles is highly recommended (normal glasses are not sufficient for eye protection) when using an air compressor. Prescription glasses do not have safety lenses.

### FOOTWEAR

Where there is the risk of heavy objects or if there is a risk of slipping on wet or slippery floors, suitable non-slip safety footwear should be worn. Protect your feet from dropping accidents.

### EAR PROTECTION

The use of ear protection is highly recommended when using air compressors. The continual noise may damage your ears.

### RESPIRATORY PROTECTION

When operating any machinery that creates dust, or when spray painting, an approved dust / filter mask must be worn. When machining concrete, man made fibres, especially MDF (Medium Density Fibre board), the resin used in these materials can be hazardous to your health. Use an approved face mask with replaceable filter.

### DO NOT OVER REACH

Do not over reach. Keep a proper footing and maintain your balance at all times. Avoid using abnormal stances and awkward body positions.

### STAY ALERT

Watch what you are doing, use common sense and never operate an air compressor under the influence, when you are tired, drinking alcohol, taking drugs or if taking medication that causes drowsiness.

# COMPLETE WARRANTY STATEMENT



Thank you for choosing this product. We stand behind the quality of our range. Please submit claims online at: [www.smga.com.au/pages/support](http://www.smga.com.au/pages/support)

Please **keep your purchase** receipt (bank statements are not accepted). Your receipt is required for any warranty claim. A photo or a copy of your receipt is acceptable providing all information is legible.

Our products are guaranteed to be free from defects in materials and workmanship for 2 years from the date of purchase.

If a manufacturing fault occurs during this period, SMG will repair or replace the product (or part) at no cost to you.

## WHAT'S COVERED

Your SMG product is covered against **defects in materials and workmanship**.

- If a manufacturing fault is confirmed, we'll **repair or replace** the faulty part or product **free of charge**.
- Replacement parts may be **new or refurbished** but will always be of equal quality.

## WHAT'S NOT COVERED

This warranty does not cover:

- Use for **hire or commercial purposes**.
- Damage from **misuse, neglect, incorrect installation**, or failure to follow instructions.
- **Rust, corrosion, dust, dirt, insect or spider blockages**.
- **Third-party or non-SMG accessories**.
- Normal wear and tear, servicing, or maintenance items.
- Freight costs if the product is **found fault-free**.
- Repair costs if the product is **found fault-free**.

## HOW TO MAKE A CLAIM

1. Please submit claims online at: [www.smga.com.au/pages/support](http://www.smga.com.au/pages/support)
2. Empty any oil or fuel before returning
3. Send the product **securely packaged** if required.
4. If the product is faulty, repairs are **free of charge**.
5. If no fault is found, **service and freight charges** will apply.

## YOUR RIGHTS

### Australia

Our goods come with guarantees that cannot be excluded under the Australian Consumer Law. You are entitled to a replacement or refund for a major failure and compensation for any other reasonably foreseeable loss or damage. You are also entitled to have the goods repaired or replaced if the goods fail to be of acceptable quality and the failure does not amount to a major failure.

### New Zealand

This warranty is in addition to your rights under the New Zealand Consumer Guarantees Act 1993.

## NEED HELP?

For assistance, or if you cannot access our online form:

**AUSTRALIA: 1300 660 457**

**NEW ZEALAND: 0800 474 876**

Email: [service.group@smga.com.au](mailto:service.group@smga.com.au)

### Smart Marketing Group Pty Ltd

33-35 Lionel Road, Mt Waverley, VIC 3149, Australia

## PARTS DIAGRAM

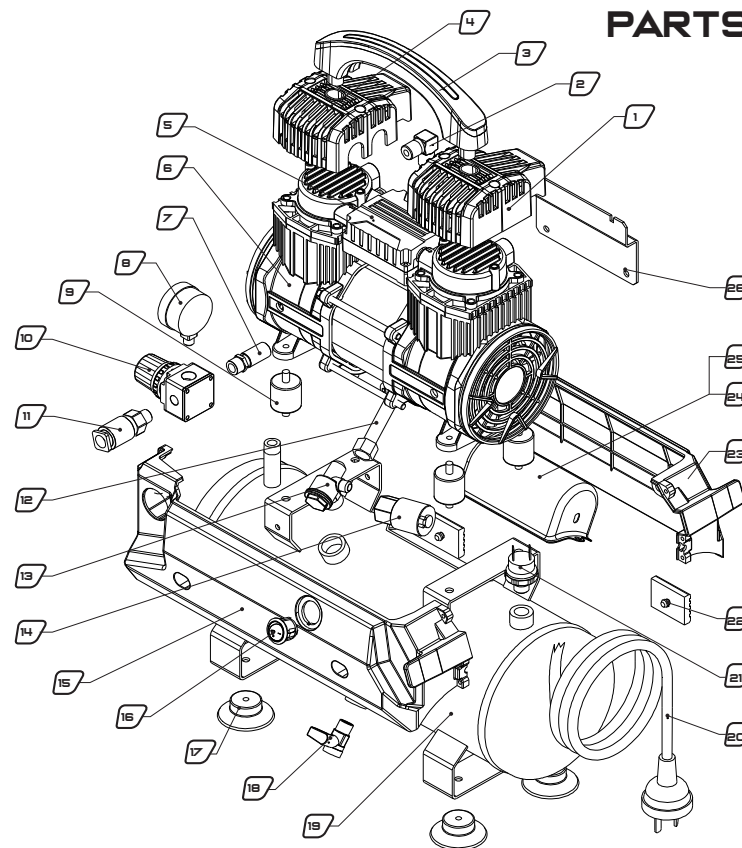

No.	Description	Unit	Qty
1	Pump head Cover A	PC	1
2	1/4 Elbow connector	PC	1
3	Handle	SET	1
4	Pump head Cover B	PC	1
5	Air filter	SET	1
6	Pump head	PC	1
7	Safety valve	PC	1
8	Pressure gauge 40	PC	1
9	Pump pad M6	PC	4
10	Regulator, 4 way	PC	1
11	Nitto Fitting	PC	1
12	High Pressure tube	SET	1
13	One-Way valve	PC	1

No.	Description	Unit	Qty
14	Solenoid Valve	SET	1
15	Side cover	PC	1
16	ON/OFF switch	SET	1
17	Rubber Pad	SET	4
18	Drain Valve	SET	1
19	Tank	PC	1
20	Power cord, 3G0.75	SET	1
21	Pressure switch	PC	1
22	Back side rubber Pad	PC	4
23	Back side Cover	PC	1
24	Capacitor cover	PC	1
25	Capacitor 20uF	PC	1
26	Wall support Plate	PC	1

**ToolPRO**

**Air**

PLU: 723466  
CODE: TP500Q

Manufactured and Packaged for  
SRGS PTY. LTD. ABN 23 113 230 050  
6 Coulthards Avenue, Strathpine,  
Queensland 4500, Australia.

Made in China